

Name: _____ ()

Class: Primary 6 _____

CHIJ ST NICHOLAS GIRLS' SCHOOL

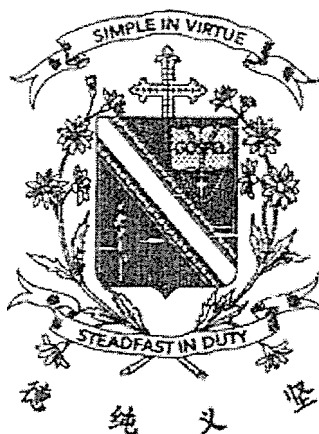

Primary 6 Preliminary Examination

SCIENCE

BOOKLET A

26 August 2021

Total Time for Booklets A and B: 1 hour 45 minutes

**28 questions
56 marks**

**Do not open this booklet until you are told to do so.
Follow all instructions carefully.
Answer all questions.**

This booklet consists of 17 printed pages.

Section A (28 x 2 marks = 56 marks)

For each question from 1 to 28, four options are given. One of them is the correct answer. Make your choice (1, 2, 3 or 4). Shade the correct oval (1, 2, 3 or 4) on the Optical Answer Sheet provided.

1. Benny found the pupa of organism Z on a tree branch as show below.

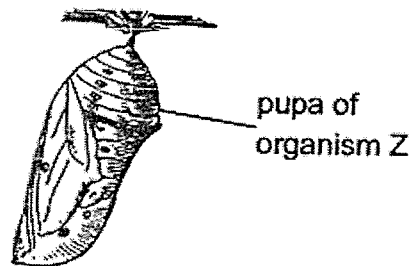

Which of the following could organism Z be?

- (1) butterfly
 - (2) mosquito
 - (3) cockroach
 - (4) grasshopper
2. The diagram below shows the growth of a bean plant.

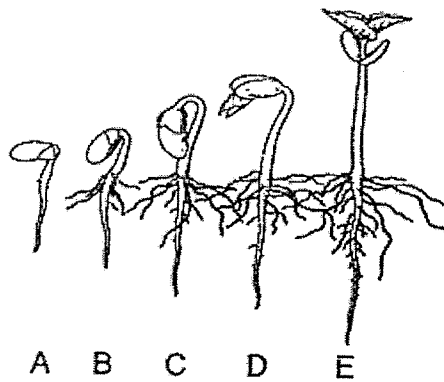

At which stage (s) is / are sunlight required for it to grow healthily?

- (1) E only
- (2) A and B only
- (3) C, D and E only
- (4) A, B, C, D and E

3. The table below shows cells P, Q, R and S. A tick (✓) shows that the cell part is present.

	P	Q	R	S
Cell membrane	✓	✓	✓	✓
Cell wall			✓	✓
Chloroplast			✓	
Cytoplasm	✓	✓	✓	✓
Nucleus	✓		✓	✓

Four statements were made about the cells.

- A Cells R and S are leaf cells.
- B Cells P, R and S are able to reproduce.
- C Cells P and Q do not have a regular shape.
- D Cells P and Q cannot control substances moving in and out of them.

Which of the following statements are true?

- (1) A and B only
- (2) A and D only
- (3) B and C only
- (4) C and D only

4. The diagrams below show the reproductive parts of a plant and a human respectively.

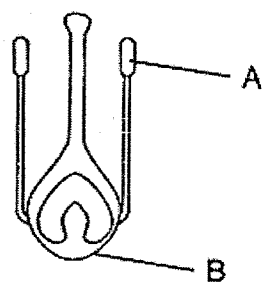

plant

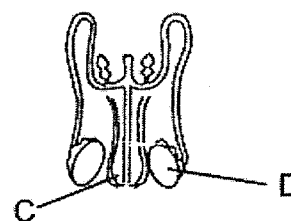

human

Which of the following parts have the same function?

- (1) A and C
- (2) A and D
- (3) B and C
- (4) B and D

5. The diagram shows a bird as it flies from flower to flower of a plant.

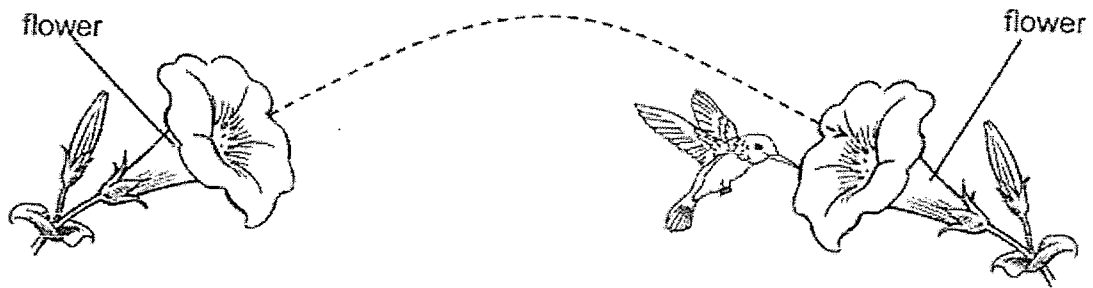

Which of the following process is the bird helping out with?

- (1) fertilisation
- (2) germination
- (3) pollination
- (4) seed dispersal

6. Rayken wanted to investigate the factors affecting germination with the four set-ups shown below. All the set-ups are given the same amount of soil and water.

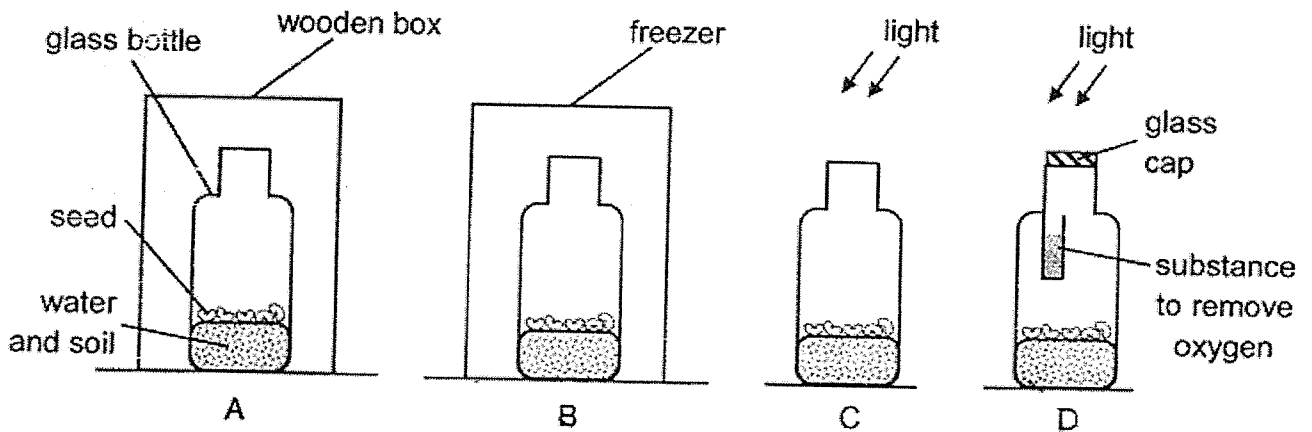

In which set-ups will the seeds most likely germinate?

- (1) A and B only
- (2) A and C only
- (3) B and D only
- (4) C and D only

7. Which of the following graphs correctly shows how carbon dioxide affects the rate of photosynthesis?

(1) rate of photosynthesis

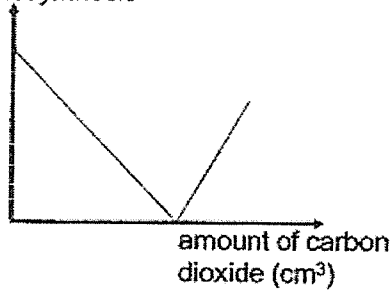

(2) rate of photosynthesis

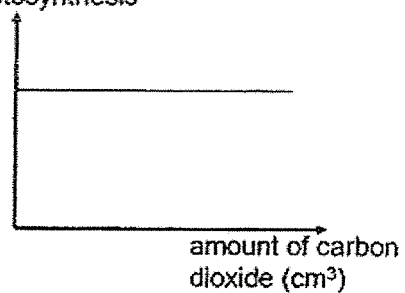

(3) rate of photosynthesis

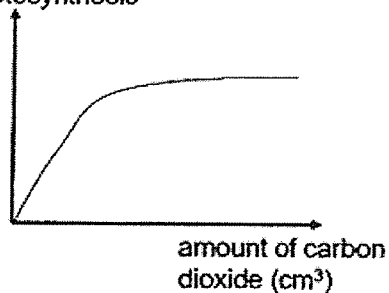

(4) rate of photosynthesis

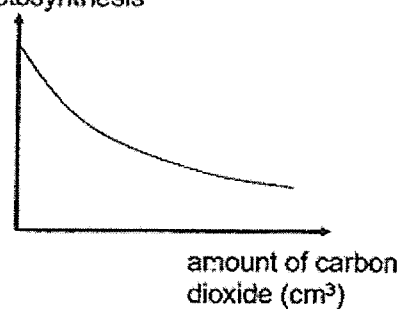

8. The diagram below shows some plants growing in and around a pond.

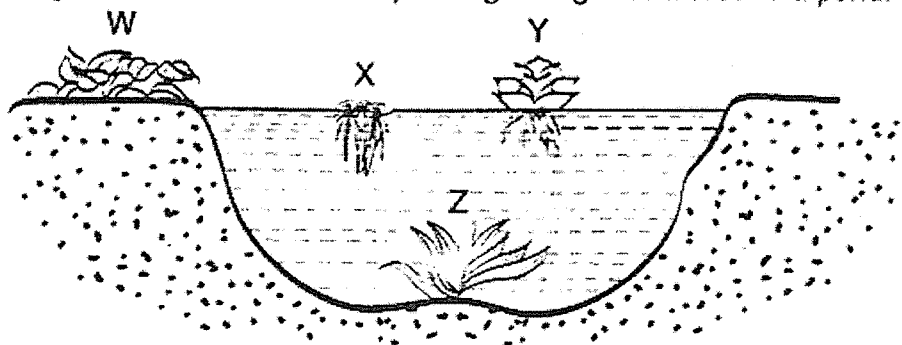

What will happen when plant X multiplies quickly?

- (1) Plant Y will not be affected.
- (2) Only plant Z will not grow well.
- (3) Plant Y and Z will not grow well.
- (4) Plants W, Y and Z will not grow well.

9. Which of the following statements are true for both the fern and bracket fungus?

- A Both of them respire all the time.
- B Both of them are non-flowering plants.
- C Fern is able to make food but the bracket fungus cannot.
- D Fern reproduces from seeds while bracket fungus reproduces from spores.

- (1) B only
- (2) A and C only
- (3) C and D only
- (4) A, B, C and D

10. The table below shows some characteristics of three organisms X, Y and Z. A tick (✓) indicates the presence of the characteristic in the organism.

Characteristic	X	Y	Z
It makes its own food.		✓	
It has three body parts	✓		
It has hair on its body.			✓
It moves from place to place.	✓		✓

Which of the following is correct?

	X	Y	Z
(1)	ant	bacteria	bat
(2)	plant	bacteria	spider
(3)	butterfly	plant	dolphin
(4)	spider	plant	bat

11. Which of the following is / are not matter?

- A air
- B light
- C cloud
- D shadow

- (1) A only
- (2) A and C only
- (3) B and D only
- (4) B, C and D only

12. Study the diagram below.

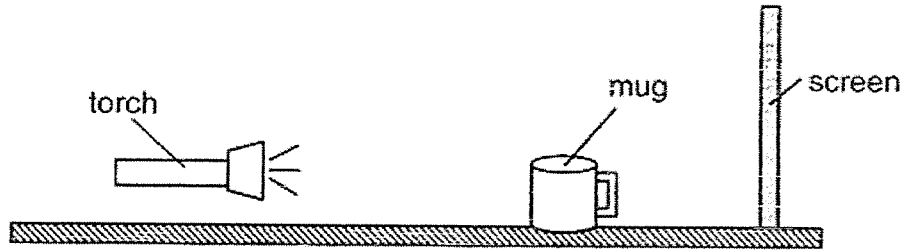

The mug was rotated and placed at different positions between the torch and screen. Which of the following shadows cannot be cast by the mug?

(1)



(2)



(3)



(4)



13. Study the classification chart below.

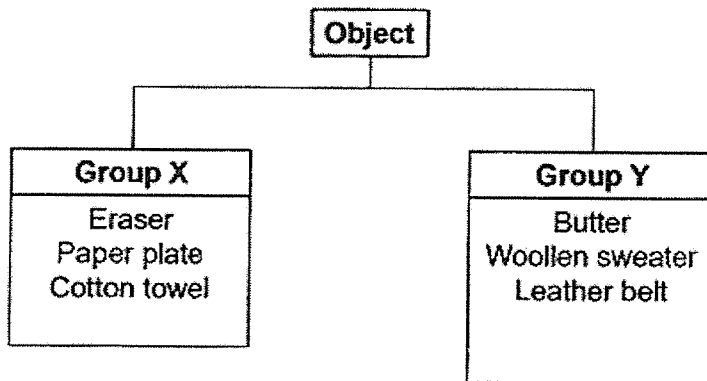

Which of the following shows the correct headings for the two groups?

	Group X	Group Y
(1)	weak	strong
(2)	opaque	transparent
(3)	waterproof	not waterproof
(4)	made of materials that comes from plants	made of materials that comes from animals

14. The diagram below shows light shining on three shapes A, B and C made of frosted glass, metal and wood respectively. They are placed at different distances from the torch.

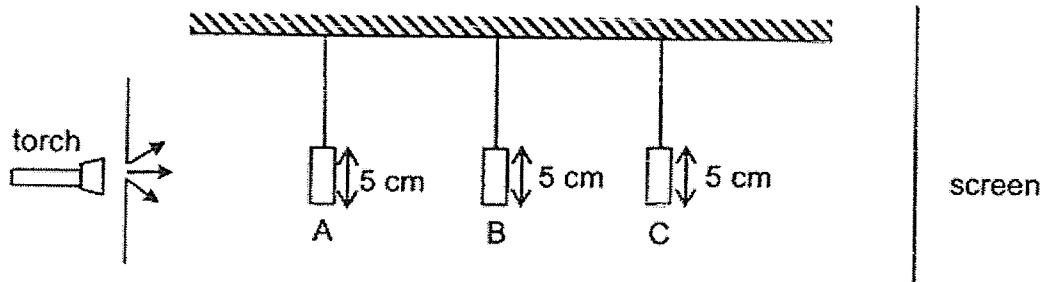

The diagram below shows the shadow cast on the screen.



Which of the following correctly represents shapes A, B and C?

	A	B	C
(1)	square	triangle	ring
(2)	square	ring	triangle
(3)	triangle	square	ring
(4)	triangle	ring	square

15. Two containers are connected by a tube as shown below.

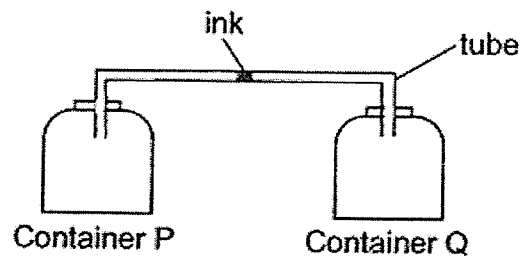

When container Q was placed in a basin of ice cubes, the drop of ink in the tube will _____.

- (1) freeze
- (2) remain stationary
- (3) move towards container P
- (4) move towards container Q

16. Two similar metal balls A and B were hung on a balance as shown below.

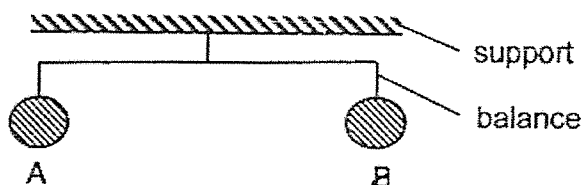

Ball B was then heated for 5 min.

Which of the following shows the correct observation of the size of the ball B and the tilt of the balance after 5 min?

	Size of ball B	Tilt of balance
(1)	increased	tilt towards ball B
(2)	increased	remained balanced
(3)	remained the same	tilt towards ball B
(4)	remained the same	remained balanced

17. Two similar pieces of glass E and F were each placed in two rooms X and Y with different temperatures respectively.

After some time, both pieces of glass were brought to room Z and the observation of the glass pieces are shown in the diagram below.



Which of the following correctly compares the difference in temperatures of rooms X and Y in comparison to room Z?

	Temperature of room X	Temperature of room Y
(1)	Higher than room Z	Lower than room Z
(2)	Higher than room Z	Same as room Z
(3)	Lower than room Z	Lower than room Z
(4)	Lower than room Z	Same as room Z

18. The graph below shows some ice being heated. After some time, the heat source was turned off and water was left to cool.

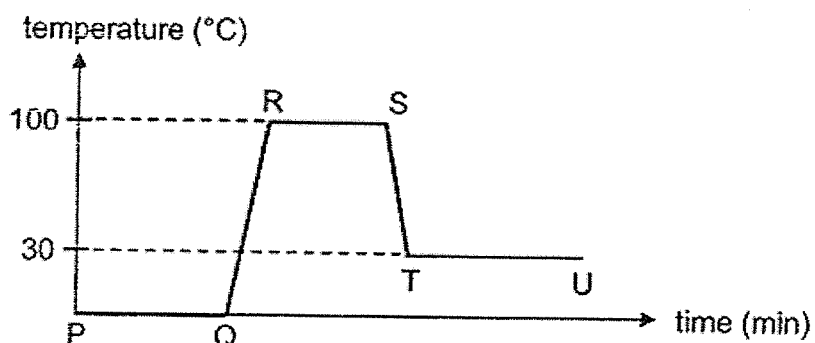

Based on the graph, which of the following statements are true?

- A Boiling takes place at R.
 - B The room temperature was 30°C .
 - C The heat source was turned off at R.
 - D There was no heat gain or heat loss from P to Q.
- (1) A and B only
 (2) A and C only
 (3) B and D only
 (4) C and D only
19. A ball was thrown upwards from position X as shown below. Position Y is the highest point the ball can reach.



Which of the following is correct?

- (1) No force is acting on the ball when it reached position Y.
- (2) Gravitational force causes the ball to change its direction of motion.
- (3) There is no frictional force acting on the ball when it moves from position X to Y.
- (4) There is no gravitational force acting on the ball when it moves from position X to Y.

20. The diagram below shows the observation made when two similar 10-kg blocks were placed on two planks made of different materials P and Q.

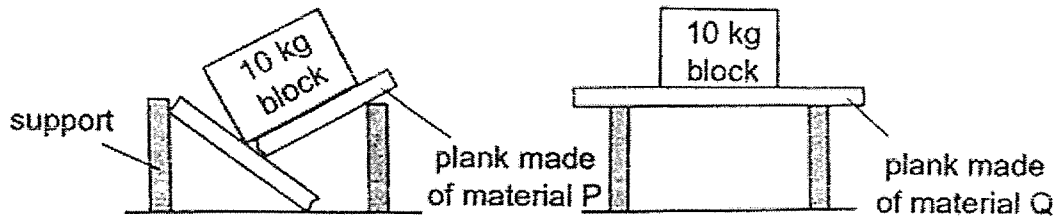

The diagram below shows the observation made when two similar 20-kg blocks were placed on two planks made of different materials Q and R.

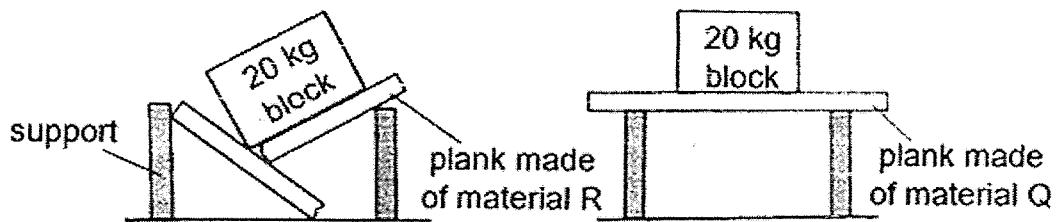

Which of the following statements about materials P, Q and R is / are correct?

- A Material Q is the strongest material.
 - B Material P is the weakest material.
 - C Material R is stronger than material P.
 - D Material R can support a 15-kg item without breaking.
- (1) A only
(2) B and C only
(3) C and D only
(4) A, B, C and D

21. The table below shows the characteristics of objects P and Q. A tick (✓) represents the presence of the characteristic.

Characteristic	Object	
	P	Q
Occupies space	✓	✓
Can be compressed		✓
Takes the shape of the container it is in	✓	✓

Objects P and Q can be represented by A, B or C in the chart shown below.

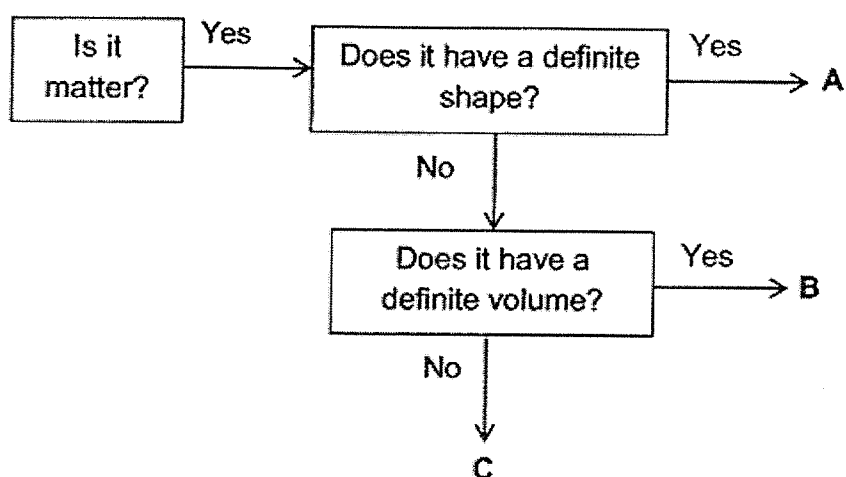

Based on the chart above, which letters A, B or C represent objects P and Q?

	Object P	Object Q
(1)	A	B
(2)	B	C
(3)	C	A
(4)	C	B

22. Jun Hao held a toy between his hands as shown. He rotated the toy by sliding one hand forward and the other hand backwards. The toy started rotating and stopped after a while.

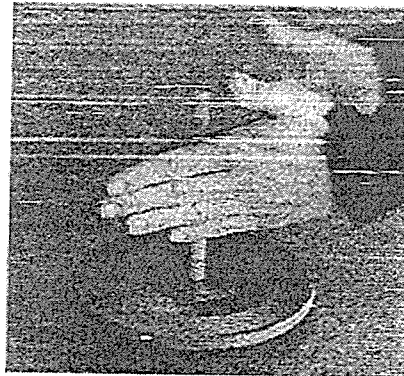

Jun Hao rotated the toy again with less force. This time, the toy did not rotate as long as before.

Which of the following statement explains this observation?

- (1) The kinetic energy of the toy was lesser than before.
 - (2) The kinetic energy of the toy was converted to heat and sound energy.
 - (3) The gravitational potential energy was greater than the mass of the toy.
 - (4) The hand was gaining heat energy from the toy, causing the kinetic energy to decrease.
23. The diagram below shows a battery-powered toy car.

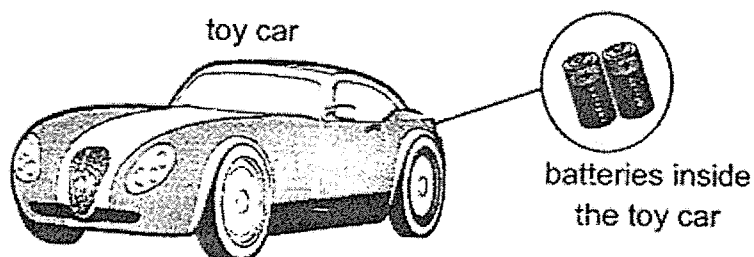

Which of the following shows the correct energy conversion that enables the car to move?

- (1) electrical energy \rightarrow kinetic energy \rightarrow heat and sound energy
- (2) chemical potential energy \rightarrow electrical energy \rightarrow kinetic energy
- (3) gravitational potential energy \rightarrow electrical energy \rightarrow kinetic energy
- (4) kinetic energy \rightarrow electrical energy \rightarrow kinetic energy \rightarrow sound energy

24. Lily set up the experiment as shown in the diagram below. The masses of magnet A and object B are 85 g and 150 g respectively. Magnet X is fixed to the table.

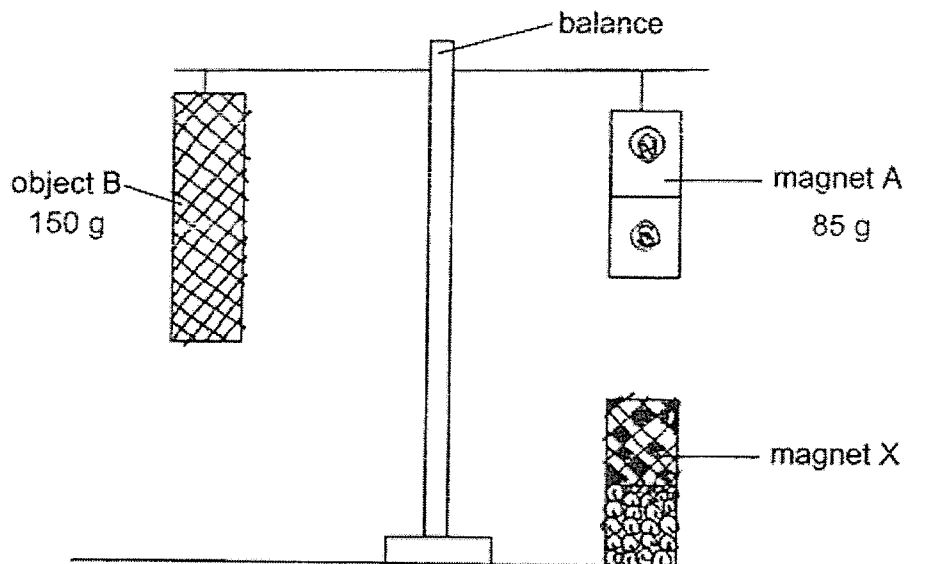

Which of the following explains how object B is balanced by magnet A?

	Poles of magnet X facing magnet A	Explanation
(1)	North	Unlike poles attract so Magnet A is pushed upwards to balance Object B.
(2)	South	Like poles repel so Magnet A is pushed upwards to balance Object B.
(3)	North	Unlike poles attract so Magnet A is pulled downwards to balance Object B.
(4)	South	Like poles repel so Magnet A is pulled downwards to balance Object B.

25. The circuit card shown below has a metal thumbtack at each end of the points A, B, C, D and E. Some of the thumbtacks are connected by wires behind the card.

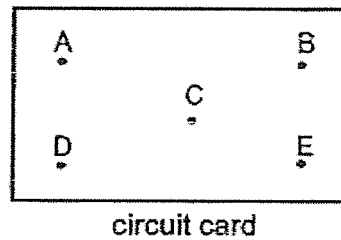
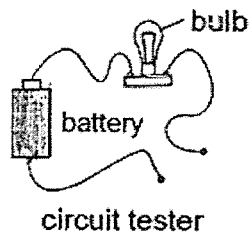

Shaun wanted to find out how the thumbtacks are connected. He connected the two ends of the circuit tester to the thumbtacks and recorded the results as shown below.

Circuit tester connected to thumbtacks at:	Does the bulb in the circuit tester light up?
A and E	No
B and C	Yes
C and E	Yes
D and A	No

From the result shown in the table above, which of the following is a possible arrangement of the wire behind the circuit card?

(1)

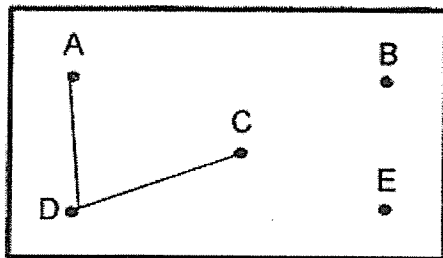

(2)

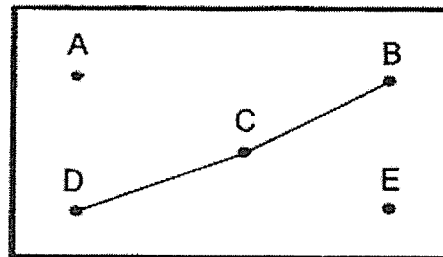

(3)

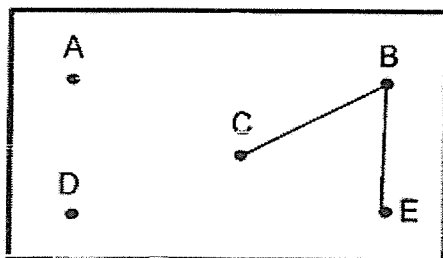

(4)

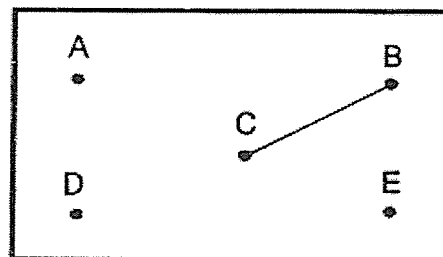

26. Study the circuits below. All the bulbs in the four circuits lit up.

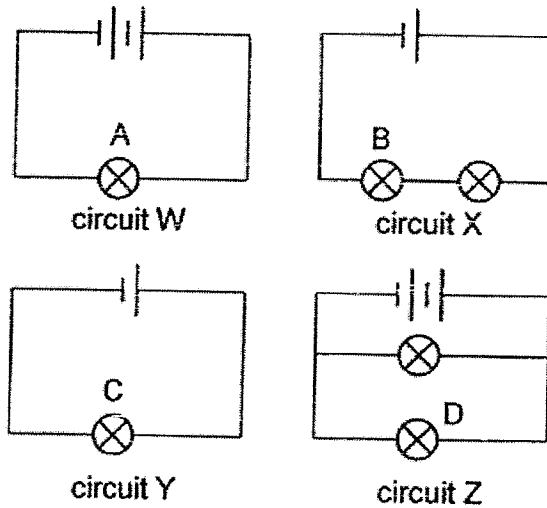

Which of the following shows the correct brightness of bulbs A, B, C and D?

Brightness of bulb			
	Low	Medium	High
(1)	A	B	C
(2)	B	C	A
(3)	C	B	D
(4)	C	A	B

27. A ceiling fan converts electrical energy to kinetic energy to produce wind when the switch is turned on. The table below shows the electrical efficiency of different brands of ceiling fans.

Brand	Amount of electrical energy needed (units)	Amount of kinetic energy generated (units)
W	100	70
X	100	90
Y	150	50
Z	150	100

Which of the above brands W, X, Y or Z is the most energy-efficient?

- (1) W
- (2) X
- (3) Y
- (4) Z

28. Siti conducted an experiment on the extension of a spring using the set-up below. Objects X, Y and Z are of different masses.

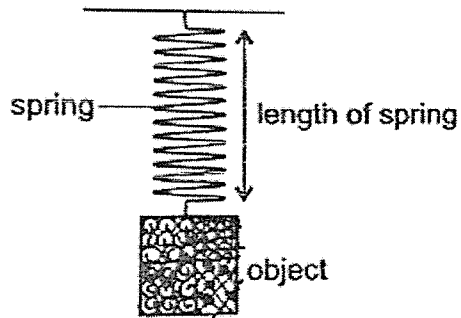

She placed different combinations of objects X, Y and Z on the spring and measured the length of the spring. Her results are as shown below.

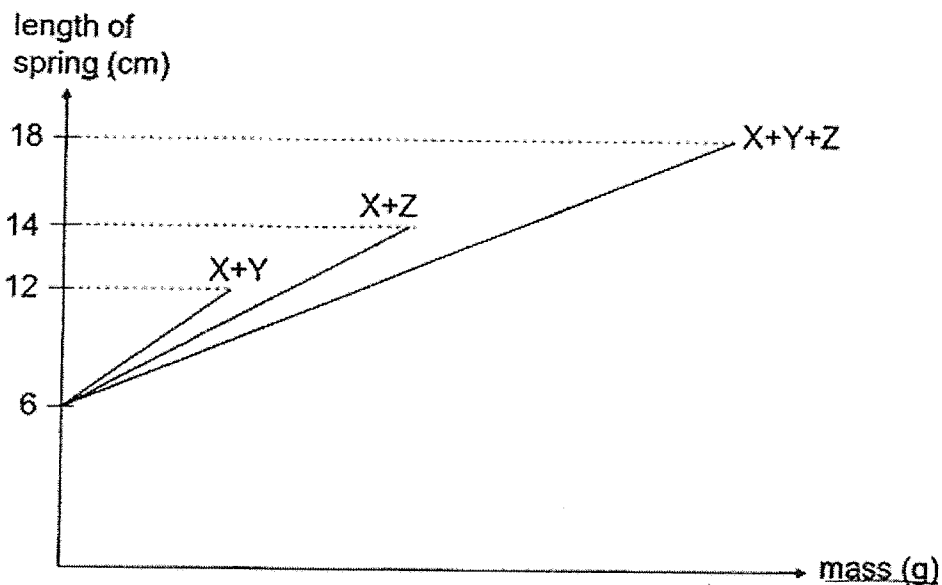

What would the extension of the spring be when only object Y was placed on the spring?

- (1) 2 cm
- (2) 4 cm
- (3) 6 cm
- (4) 12 cm

~End of Booklet A~

Name : _____ ()

Class : Primary 6 _____

CHIJ ST NICHOLAS GIRLS' SCHOOL

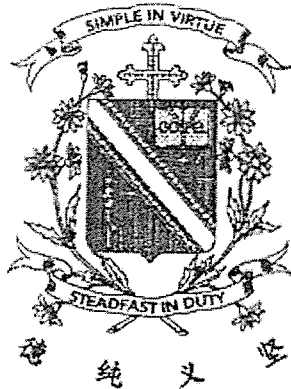

Primary 6 Preliminary Examination

SCIENCE

BOOKLET B

26 August 2021

Total Time for Booklets A and B: 1 hour 45 minutes

13 questions
44 marks

Do not open this booklet until you are told to do so.
Follow all instructions carefully.
Answer all questions.

This paper consists of 14 printed pages.

Booklet A	56
Booklet B	44
Total	100

Section B (44 marks)

For questions 29 to 41, write your answers in this booklet.

The number of marks available is shown in the brackets at the end of each question or part question.

29. The chart below shows how some animals are classified.

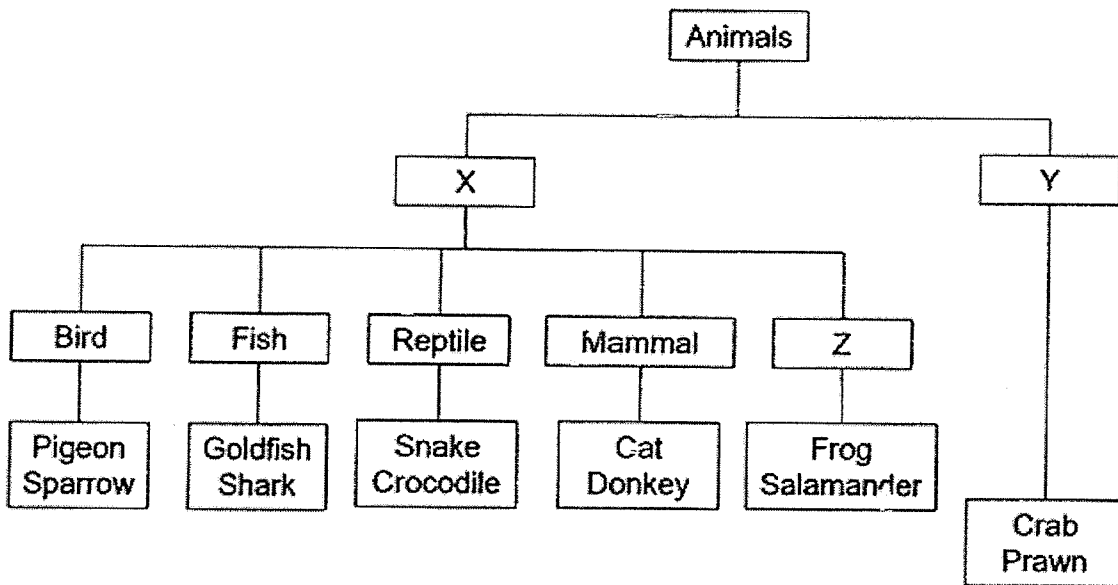

(a) All the animals in Group Y have a common feature in their body structure which group X does not have. What is this common feature? [1]

(b) What does Group Z represent? [1]

(c) Sally said that whales should be grouped under fish. Do you agree with her? Explain your answer. [1]



30. The diagram below shows the blood flow in some parts of the human body.

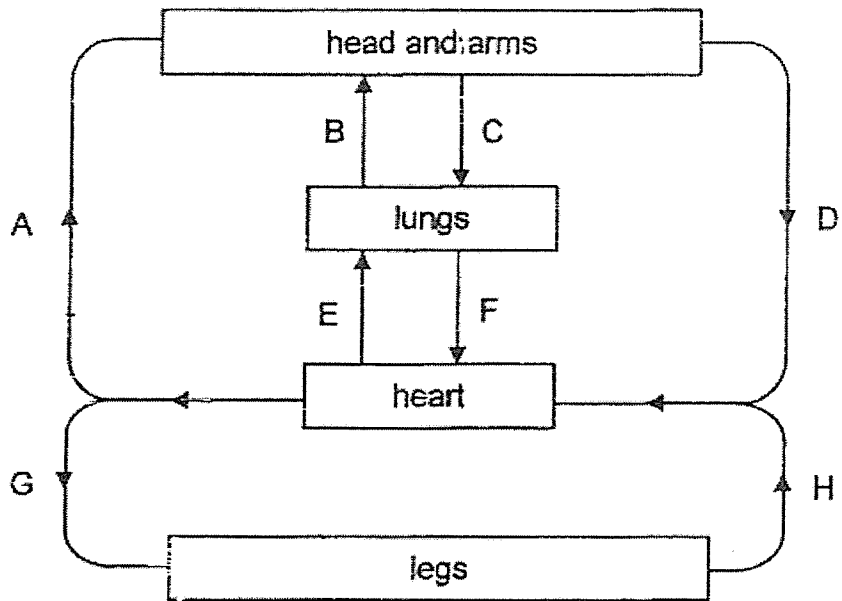

(a) Which two arrows are drawn incorrectly? [1]

(b) Blood at E contains a greater amount of gas X than at F. What is gas X? Give a reason for your answer. [1]



31. The diagram below shows a plant placed in a beaker of red-coloured water. The outer ring of a section of the stem of the plant was removed. The plant is left in the sun for a day.

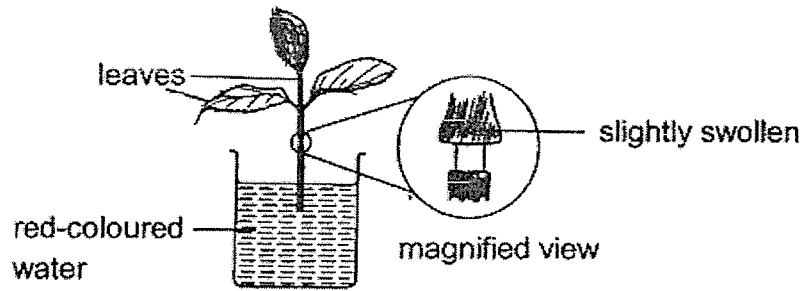

- (a) What would happen to the colour of the leaves after a day? Give a reason for your answer. [2]

- (b) The upper part of the stem swelled slightly after a day. Explain why. [1]

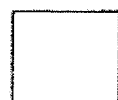

32. Mrs Ling conducted an experiment using the two set-ups shown below.

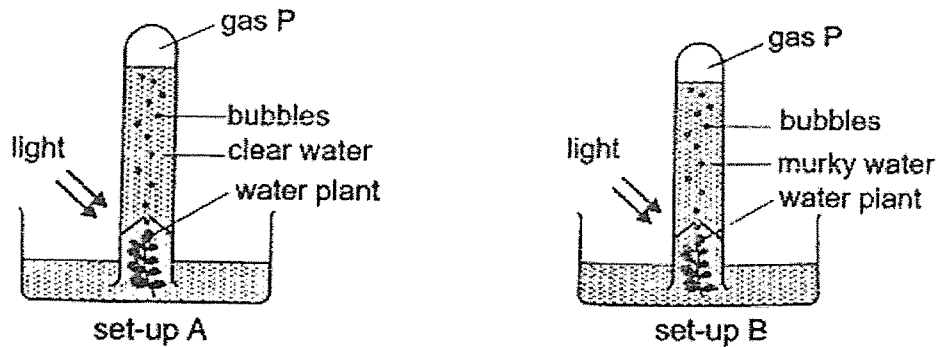

She measured the amount of gas P collected at the top of the inverted test tube over a period of one hour.

(a) What is gas P? [1]

(b) Based on the given information, what is the aim of Mrs Ling's experiment? [1]

The graph below shows the results Mrs Ling obtained.

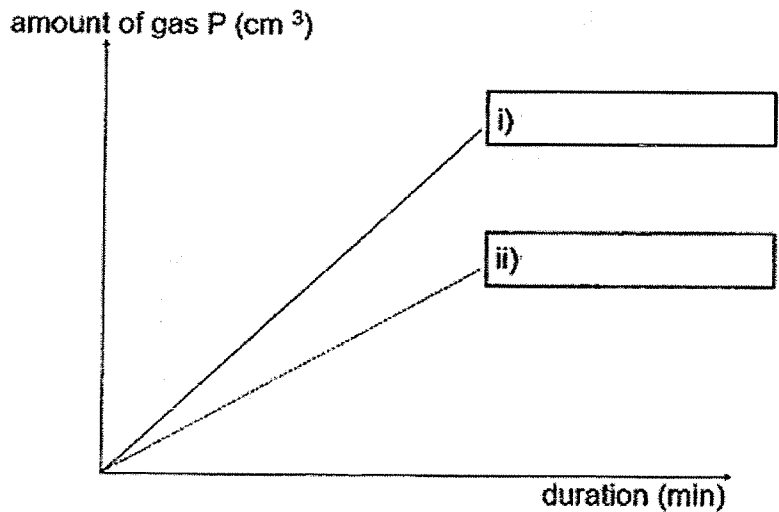

(c) On the same graph above, label set-up A and set-up B in the respective boxes. [1]

(d) Based on the results of the experiment, explain why it is advisable to use water in set-up A for keeping fish and plant in a tank. [1]



33. Aileen dropped a 5-g mass from a height of 2 m and recorded the time taken for it to reach the ground. She then made a toy by attaching a plastic sheet to the same 5-g mass. She wanted to find out how the size of the plastic sheet affects the time taken by the 5-g mass to reach the ground when dropped from a height of 2 m.

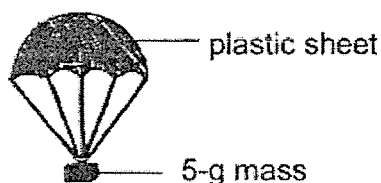

The experiment was repeated with plastic sheets of different sizes and the results were recorded in the table below.

Size of plastic sheet (cm ²)	Time taken for the 5-g mass to reach the ground (units)
without plastic sheet	1
100	3
200	6
300	8

- (a) Based on the results, what can be concluded from the experiment? [1]

- (b) What was the purpose of dropping the 5-g mass without the plastic sheet? [1]



- (c) Fruits G and H have the same mass of seeds but different sizes of the wing-like structures.

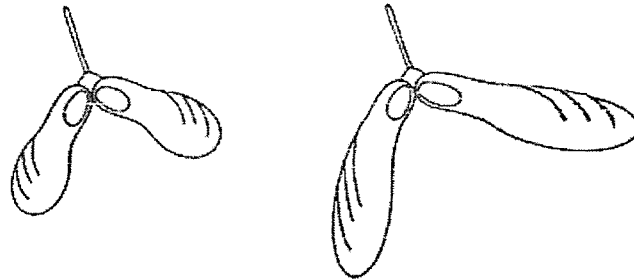

fruit G

fruit H

Based on Aileen's experiment, which fruit G or H would be dispersed further away from the parent plant when dropped from the same height? Explain your answer. [2]

34. The diagram below shows the female reproductive system of a human.

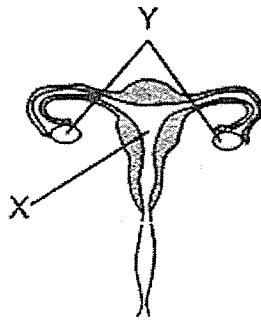

- (a) What is the function of X? [1]

- (b) If one of part Y is removed, would the female still be able to reproduce? Give a reason for your answer. [1]



35. The set-up below was placed in a dark room to investigate which material was best for reflecting light. The experiment was first conducted using material P and repeated with materials Q and R.

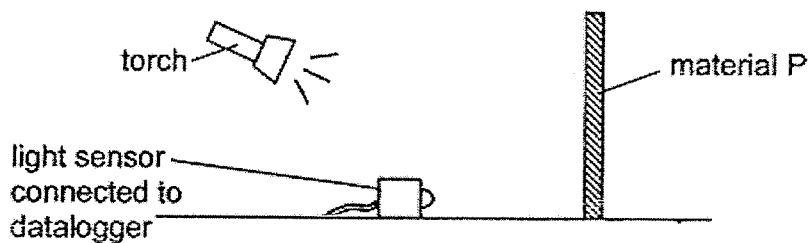

The results were recorded in the table below.

Material	Amount of light detected (units)
P	280
Q	100
R	420

- (a) Based on the above results, arrange the materials P, Q and R according to their transparency. [1]

_____ , _____ , _____
 (allows most light to pass through)

_____ , _____ , _____
 (allows least light to pass through)

- (b) Which material should be used to make a safety vest for cyclists to wear at night? Give a reason for your answer. [2]



36. Arif conducted an experiment using the set-up below.

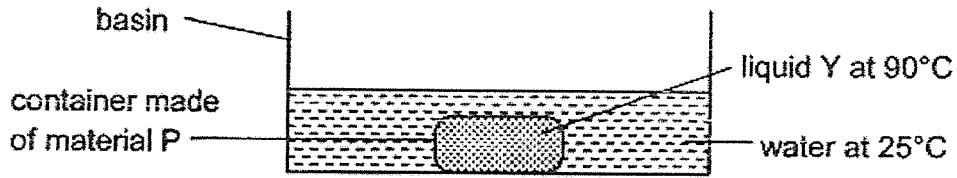

He measured the temperature of liquid Y in the container over a period of time. The experiment was repeated with another container made of material Q and the results are shown in the graph below.

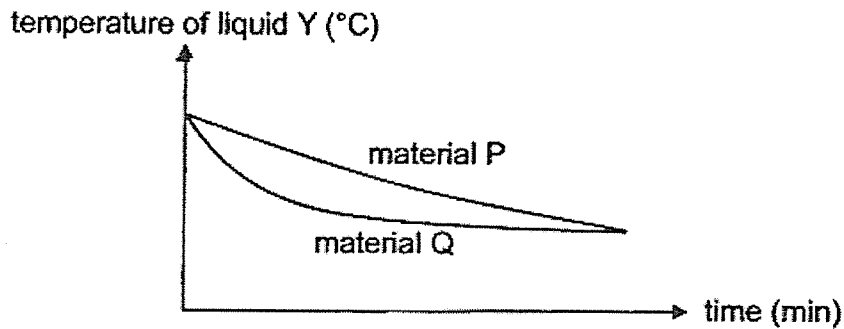

Arif wanted to bring hot food and cold drinks for a picnic. He wanted to keep the food hot and the drinks cold.

(a) Which material(s) would be more suitable to be used to make such containers? [1]

i) Material for container carrying hot food: _____

ii) Material for container carrying cold drinks: _____

(b) Explain your choice for (ai)

(c) Why should the size of the containers made of P and Q be kept constant? [1]



37. The set-up below shows a nichrome coil converting electrical energy to heat energy to heat up water.

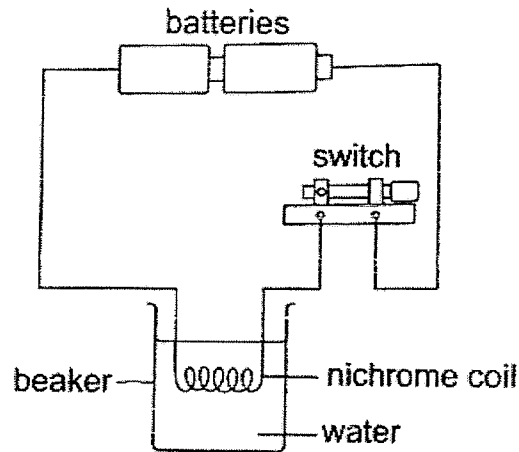

- (a) What property of the nichrome coil allows the water in the beaker to heat up? [1]

- (b) Suggest one change to the set-up so that the water in the beaker will boil faster. Explain your answer. [2]

Change: _____

Explain: _____



38. The diagram below shows a wind turbine built at the centre of an expressway. The moving cars will cause the air around the turbine to move, which in turn causes the turbine to rotate. As the turbine rotates, there is electricity generated and is used to power the lights along the expressway at night.

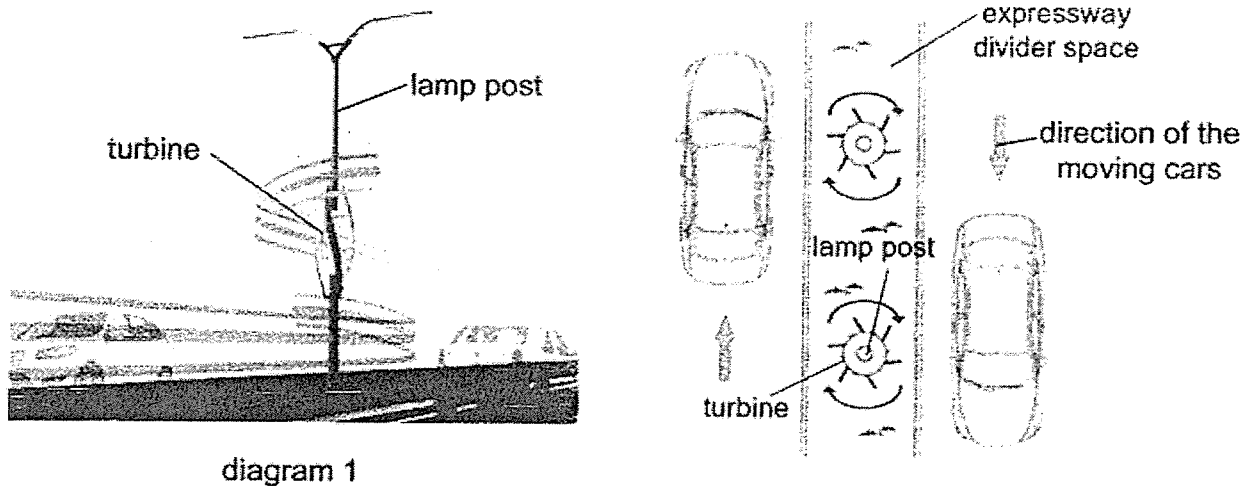
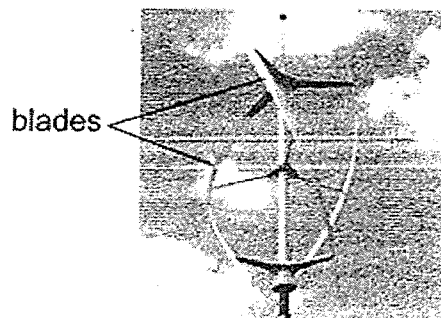

diagram 1

- (a) What is the source of energy that turns the turbine in diagram 1? [1]

- (b) State one advantage of obtaining electricity from such a method. [1]

The diagram below shows the design of the blades of the turbine. They are normally slim and light.



- (c) Give a reason why lighter blades are better than heavier blades? [1]



39. Zac sprayed two similar pieces of cloth P and Q with some water and recorded their masses. He folded cloth Q and hung both P and Q in the garden as shown in the diagram below.

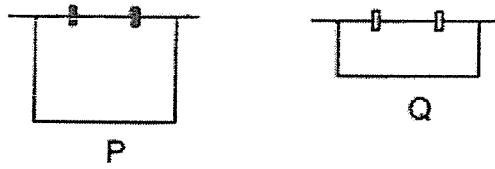

The mass of cloth P and Q were recorded at regular intervals as shown in the graph below.

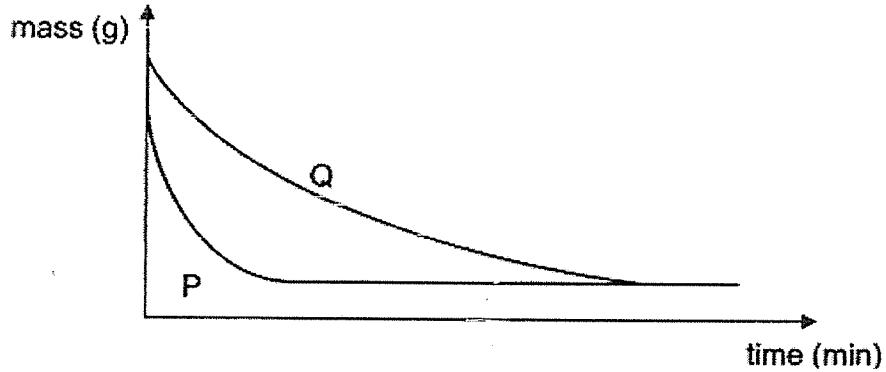

- (a) Explain why the mass of cloth P and Q decreased as time passes. [1]

- (b) Based on the graph, did Zac conduct a fair test? Explain your answer. [2]

- (c) From the graph, how can you tell when both pieces of the cloth are completely dry? [1]

- (d) State one other factor that affects the time taken for the cloths to dry. [1]

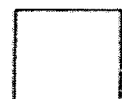

40. Elaine set up an experiment as shown below. She pulls the object against the elastic band and released the object. The object moved across the board.

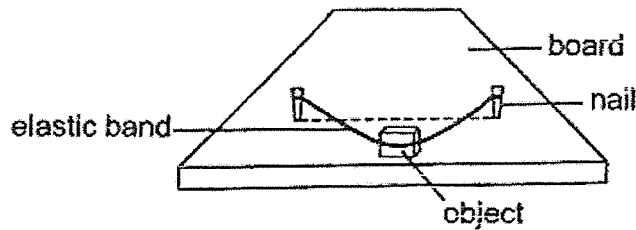

- (a) What are the force(s) acting on the object after Elaine released it? [1]

Elaine repeated her experiment using objects of different sizes. These objects are of the same mass and material. She recorded her results as shown below.

Object	Area of object in contact with the board (cm ²)	Distance moved by the object (cm)
X	30	15
Y	50	15
Z	60	15

- (b) Based on the results, did the area of the object in contact with the board affect the distance travelled by the object? Explain your answer. [1]

- (c) Other than pulling the elastic band further, what can Elaine do to the set-up so that the object can move a further distance? Explain your answer. [2]



41. Refer to set-up 1 below. A toy car, made of steel, was released from X of a plastic ramp. The time taken for it to move from X to Y and then from Y to Z was taken.

The same experiment was then repeated with object A placed under the ramp as shown in set-up 2.

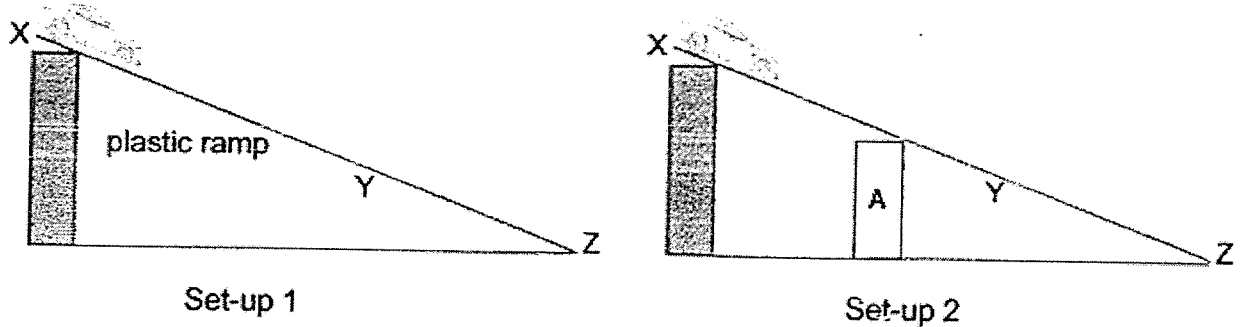

The table below shows the results from the 2 set-ups.

	Time taken (units)	
	X to Y	Y to Z
Set-up 1	15	8
Set-up 2	10	12

- (a) Based on the information above, what is object A likely to be? [1]

- (b) Give a reason for the difference in time taken for the toy car to travel from X to Y in the two experiments. [1]

- (c) The ramp in set-up 2 was replaced with an iron ramp. Will the time taken for the toy car to move from X to Y be longer, shorter or the same as compared to the results given for set-up 2 in the table? Explain your answer. [2]

~ End of paper ~

